

**CASE
HISTORY
REPORT**

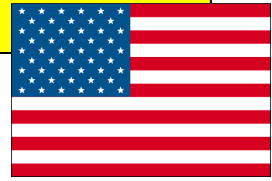

INPRO/SEAL



Company name: **CELANESE**

Location: **Bishop TX, USA**

Industry : **Chemical**

Celanese is a global leader in the chemical industry. The Celanese plant in Bishop – Texas, used INPRO/SEAL AIR MIZER on screw conveyor since 4 years.

20 equipments are fitted with forty ARTICULATING Air Mizer DESIGN and works without any concerns.



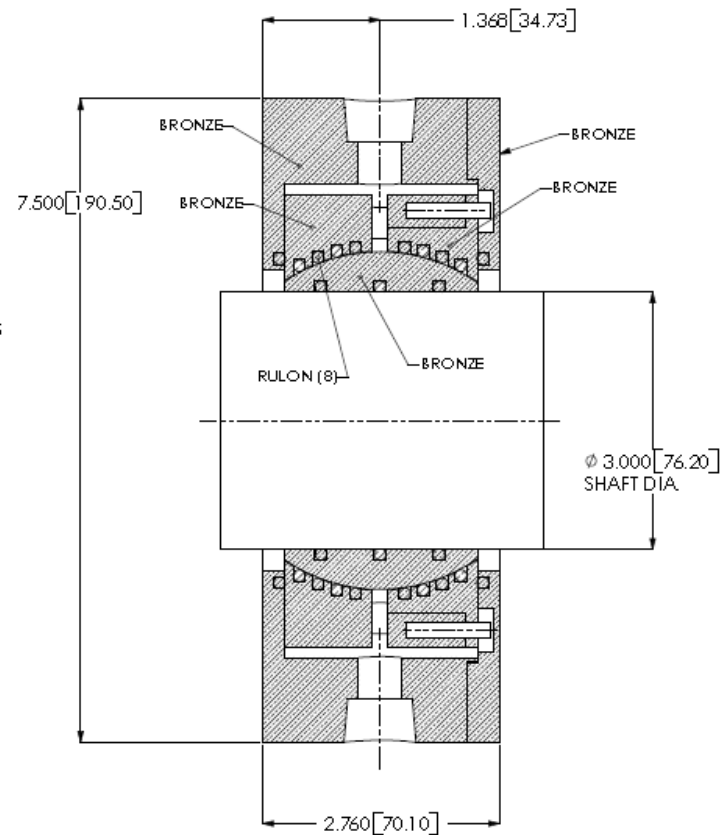
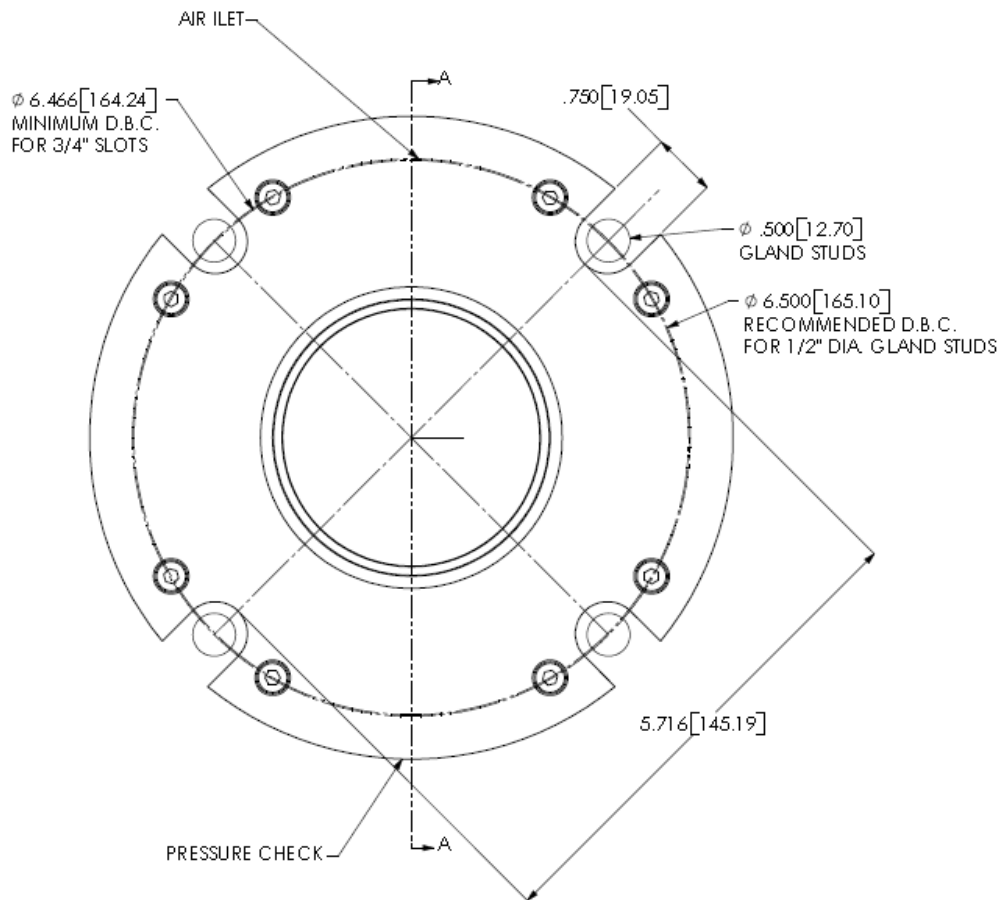

SECTION A-A

THIS DRAWING HAS BEEN ISSUED FOR APPROVAL ONLY.

- APPROVED AS IS
- APPROVED AS NOTED
- NOT APPROVED

APPROVED SIGNATURE

PATENT PENDING

INPRO/SEAL PART NO.
9965-A-29052-5

SHEET 1 OF 1



19 APR 04 NH O.D. VAS 10"	THE DRAWING BEING THE PROPERTY OF THE COMPANY AND IS TO BE KEPT IN CONFIDENCE AND NOT TO BE REPRODUCED OR TRANSMITTED IN ANY FORM OR BY ANY MEANS, ELECTRONIC OR MECHANICAL, INCLUDING PHOTOCOPYING, RECORDING, OR BY ANY INFORMATION STORAGE AND RETRIEVAL SYSTEM, WITHOUT THE WRITTEN PERMISSION OF THE COMPANY.	U.S. PATENTS 6,040,441 6,022,022 6,464,400 6,464,400 6,464,400 6,464,400 6,464,400	THOMAS CONVEYOR INPRO/SEAL DATE: 17 JAN 03 DRAWN BY: 4P4 TNO8197	
------------------------------	--	---	--	--

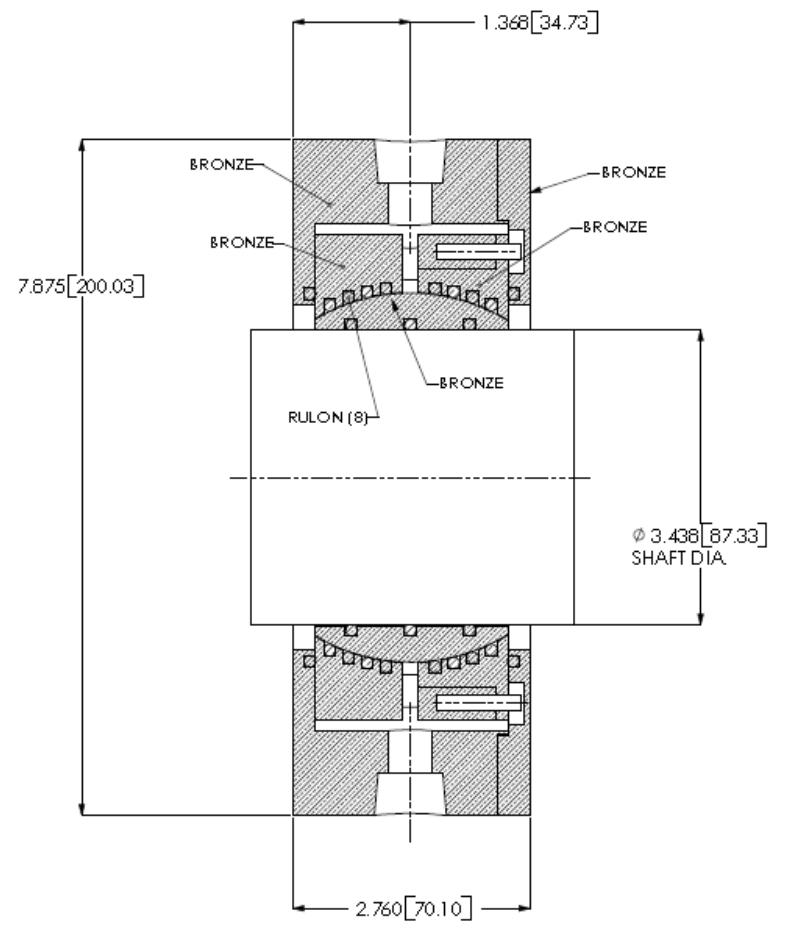
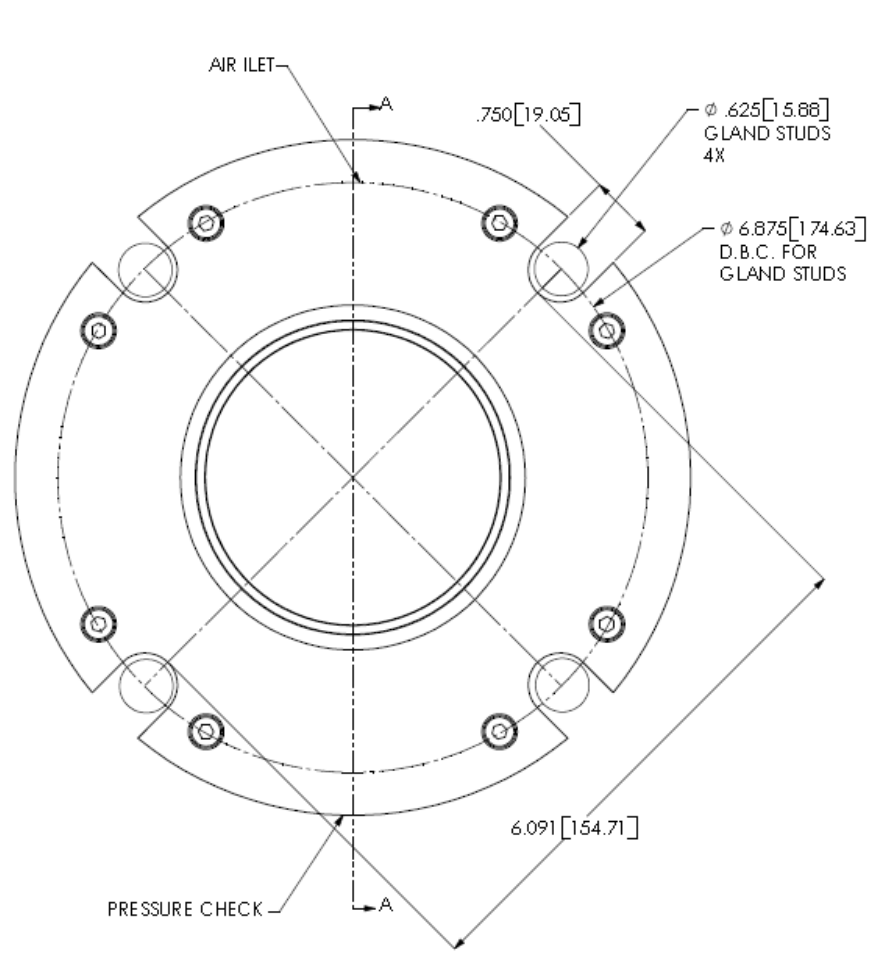

SECTION A-A

PATENT PENDING

INPRO/SEAL PART NO.
9965-A-29172-5

THIS DRAWING HAS BEEN ISSUED FOR APPROVAL ONLY.

APPROVED AS IS

APPROVED AS NOTED

NOT APPROVED

APPROVED SIGNATURE



REV	DATE	DESCRIPTION

U.S. PATENTS		
8,232,000	8-20-02	
8,232,001	8-20-02	THOMAS CONVEYOR INPRO/SEAL DATE: 3-APR-03 DRAWN BY: TN08229
8,232,002	4-24-02	
8,232,003	4-24-02	
8,232,004	4-17-02	
8,232,005	4-17-02	
AND OTHER FOREIGN PATENTS		